

HY series HY01602

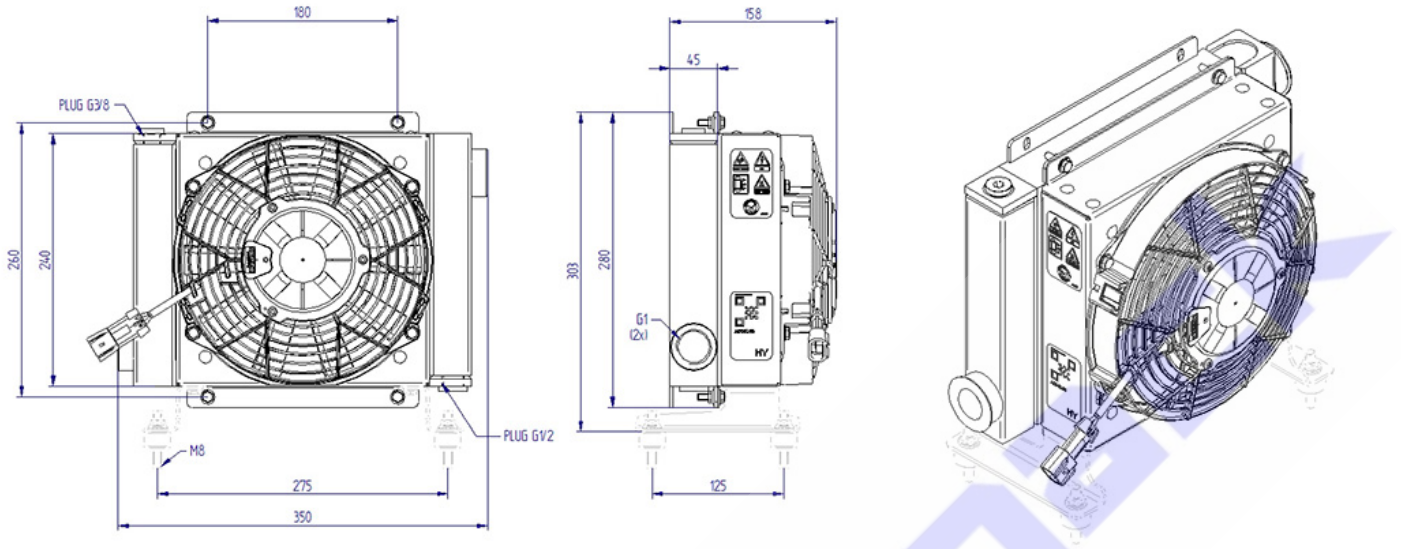

Technical data

Item	Oil flow [l/min]	Capacity [l]	Weight [kg]	Rpm	Voltage [V]	Frequency [Hz]	Current absorption [A]	Power [W]	Ø Fan [mm]	Air flow [m³/h]	Noise level [db(A)]
HY01602	10-90	0.7	6,5		12		7,30	110	225	615	66,5
HY01604	10-90	0.7	6,5		24		3,80	125	225	635	67,3

Performance

Pressure drop

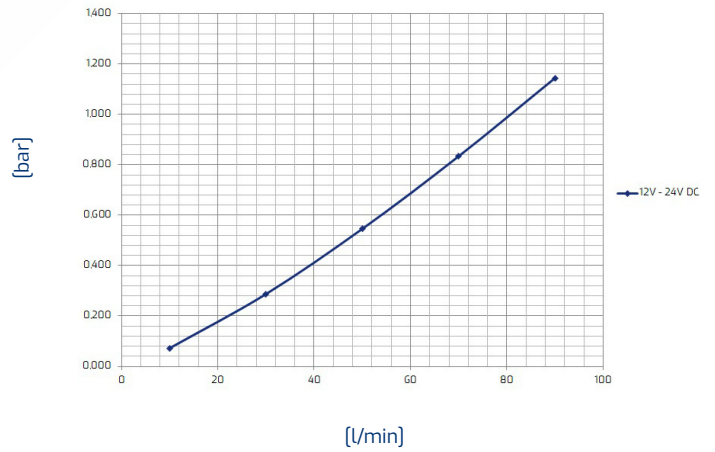
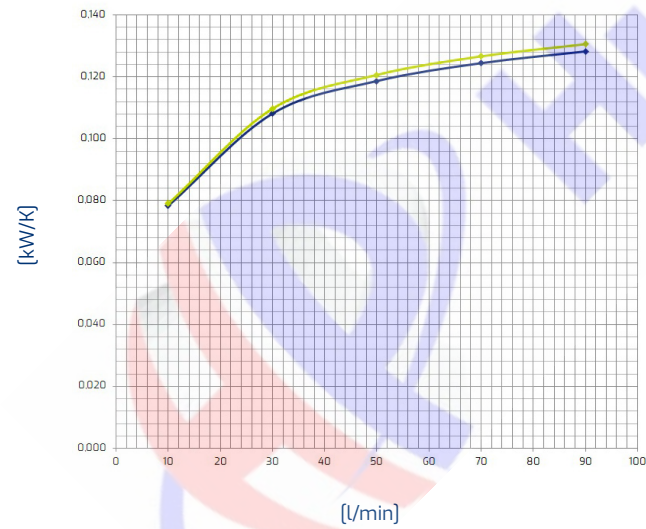

Oil T 80°C
T Amb. 40°C

Viscosity - ISO VG 32 Oil					
Oil	22	32	46	68	150
Correction factor	0,8	1	1,2	1,6	3